

LXE1721 AUDIOMAX EVALUATION KIT USER'S GUIDE



LXE1721 Evaluation Board Quick Start Guide

The LXE1721 Evaluation Board is a fully functional stereo Class-D amplifier. Connection to a single output power supply, two speakers, and an audio source is all that is required to begin evaluating the amplifier.

Board Setting

1. **Power and Ground Connections:** The terminal JP1 is for the power supply connection. Vcc is connected to the positive polarity of the power supply or battery (+7V ~ +15V); the GND is connected to the negative polarity of the power supply or battery. Please make sure your power supply polarity connection and supply voltage is correct before you begun to evaluate the board.
2. **Speaker Connections:** JP5 and JP6 are the speaker outputs. JP5 is for the left channel (CH1) and JP6 is for the right channel (CH2). Connect speaker "+" and "-" to "LOUT+/ROUT+" and "LOUT-/ROUT-" of JP5/JP6. This evaluation board is designed for standard 4 ohm speaker loads. For different impedance speakers, the output frequency response is not optimized unless the LC filter design is modified. For speaker impedance of less than 4 ohms, care must be exercised to prevent from overdriving the amplifier system. This could result in inductor saturation if the output current is too high and further cause damage to the MOSFETs. A power supply set at 6A current limit is recommended.
3. **Audio Input Connections:** JP2, JP2A, RCA1 and RCA2 are the audio input connections. JP2/JP2A support differential audio inputs, and RCA1/RCA2 are for single-ended audio inputs. When audio inputs are differential, the positive audio inputs are connected to LIN+/RIN+ pin, while the negative inputs are connected to LIN-/RIN- pin of the JP2/JP2A terminals. J1 and J2 jumpers are left open when using differential inputs. When audio inputs are single-ended, the audio source can either be connected to terminal JP2/JP2A, or to RCA inputs RCA1/RCA2. In the single-ended configuration, jumpers J1 and J2 must be closed so that the LIN-/RIN- audio inputs are connected to Ground.
4. **SLEEP/MUTE Connections:** JP4 is the jumper terminal to select ON/OFF control for SLEEP and MUTE functions. To enable the amplifier, both jumpers should be set to "OFF" (SLEEP is OFF, and MUTE is OFF).
5. **Pre-amp Output Connections:** JP3 is the header for stereo, single-ended pre-amp outputs, "LPREOUT – GND – RPREOUT". These outputs are provided to drive other crossover networks or to support additional power amplifiers such as for a Subwoofer speaker system.

APPLICATION SCHEMATIC

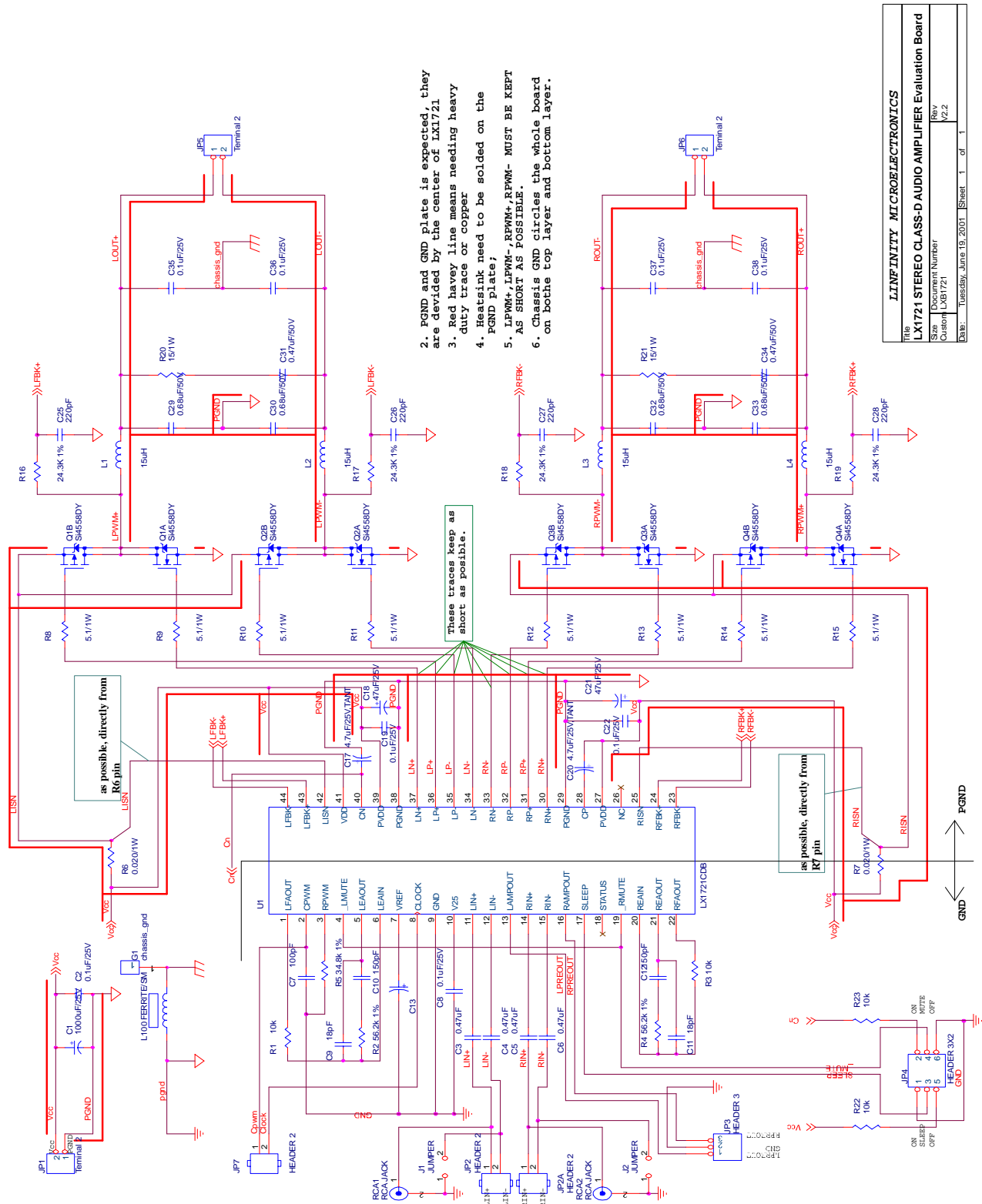

2. PGND and GND plate is expected, they are divided by the center of LX1721
3. Red heavy line means needing heavy duty trace or copper
4. Heatsink need to be soldered on the PGND plate;
5. LPWM+, RPWM+, RPWM- MUST BE KEPT AS SHORT AS POSSIBLE.
6. Chassis GND circles the whole board on both top layer and bottom layer.

These traces keep as short as possible.

as possible, directly from R7 pin

File	LINFINITY MICROELECTRONICS		
Part	LX1721 STEREO CLASS-D AUDIO AMPLIFIER Evaluation Board		
Docu	Docu	Rev	Rev
Custom	LX1721		V2.2
Date:	Tuesday, June 19, 2001	Sheet	1 of 1

FIGURE 1 - LX1721 SCHEMATIC

APPLICATION SCHEMATIC (CONTINUED)

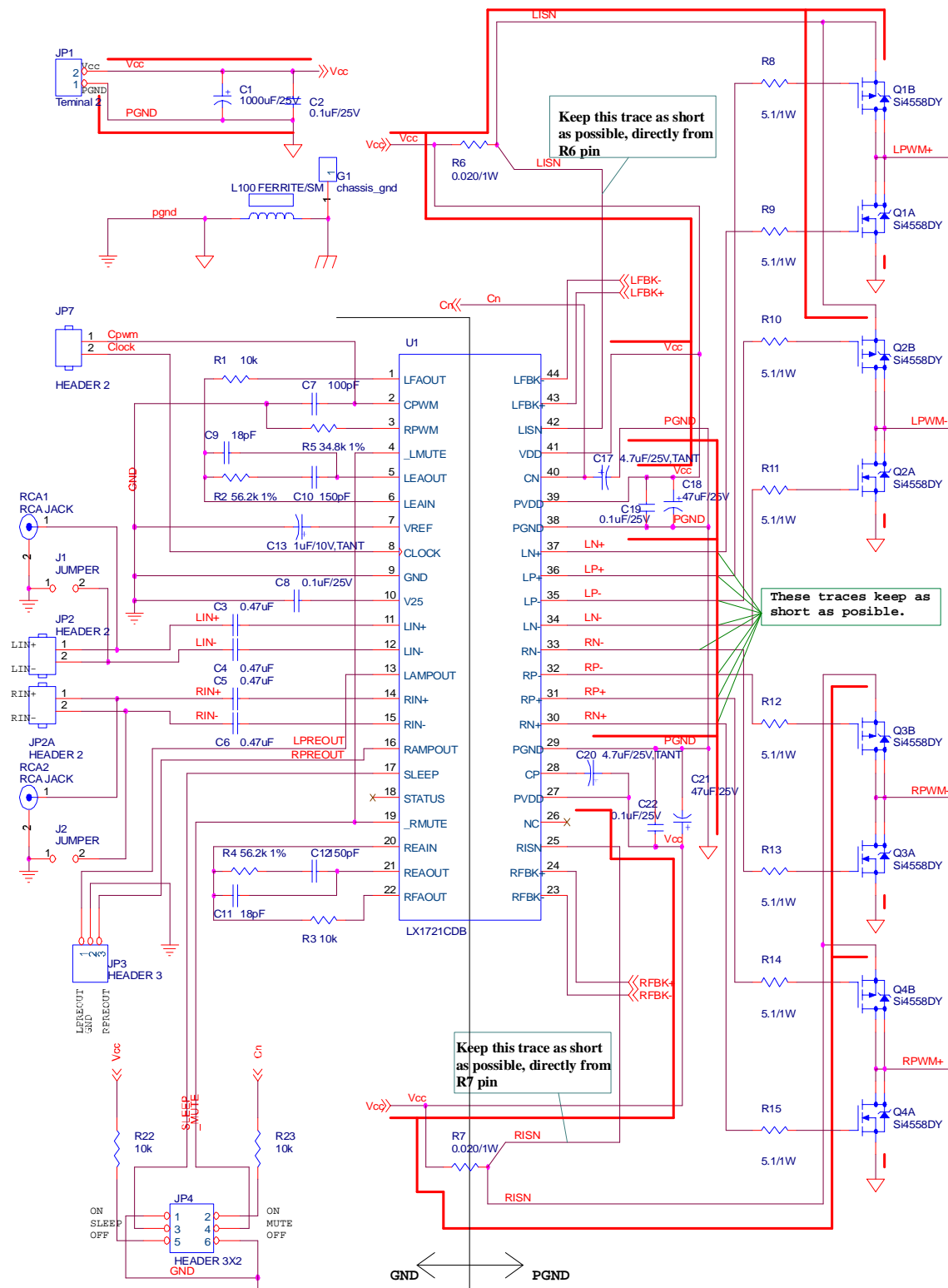
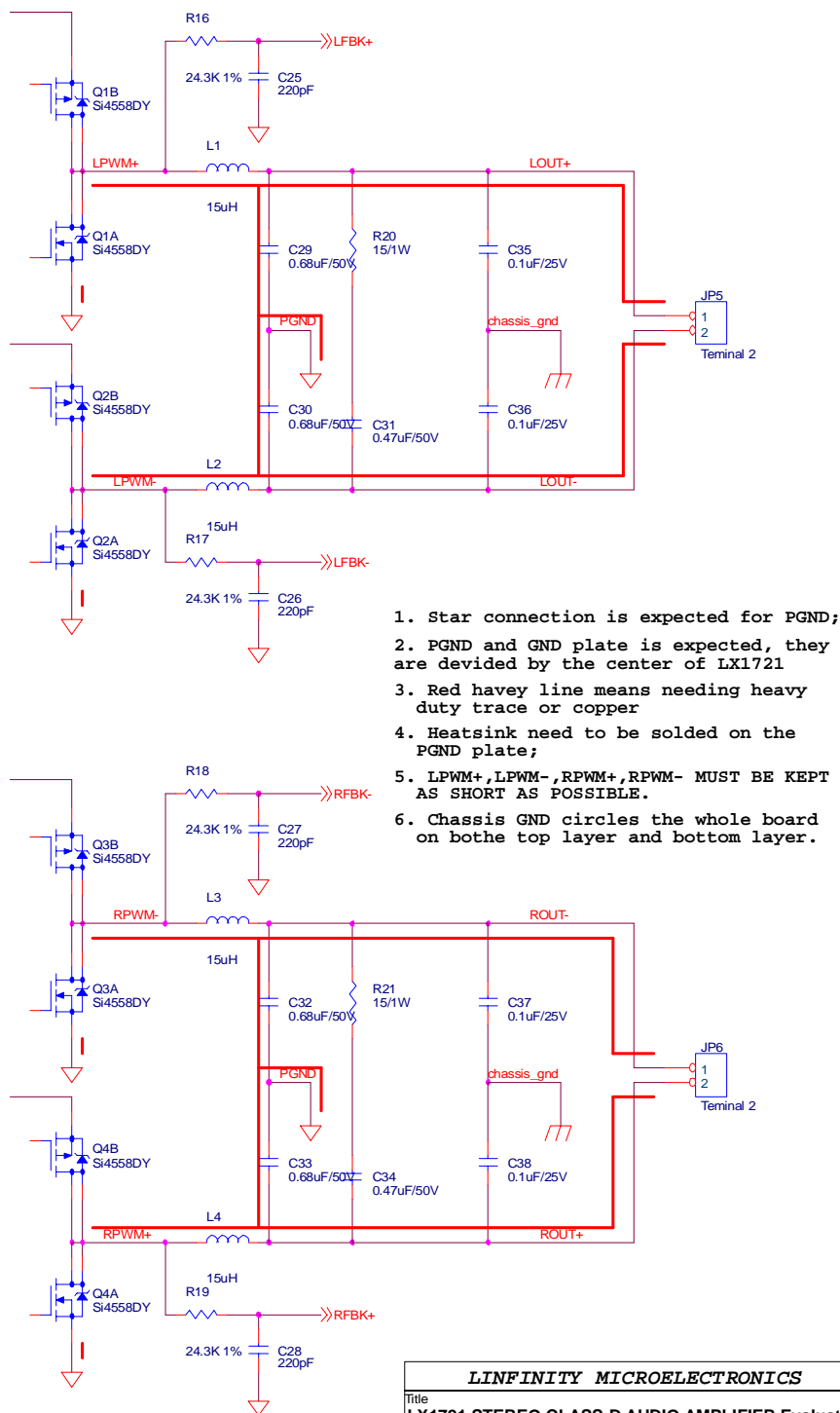

FIGURE 1A - LXE1721 SCHEMATIC (VIEW OF LX1721 SECTION)

APPLICATION SCHEMATIC (CONTINUED)



LINFINITY MICROELECTRONICS		
Title LX1721 STEREO CLASS-D AUDIO AMPLIFIER Evaluation Board		
Size Custom	Document Number LXB1721	Rev V2.2
Date: Tuesday, June 19, 2001	Sheet 1	of 1

FIGURE 1B - LXE1721 SCHEMATIC (VIEW OF OUTPUT SECTION)

BILL OF MATERIALS**MISCELLANEOUS COMPONENTS**

Line Item	Part Description	Manufacturer & Part #	Case	Reference Designators	Qty
1	IC, Controller	LINFINITY LX1721CDB	QSOP 44	U1	1
2	IC, N & P – Channel MOSFET	SILICONIX Si4558DY	SO-8	Q1, Q2, Q3, Q4	4
3	Ferrite Bead, 1000 Ohm	MURATA BLM41P102SGPT	1206	L100	1
4	Printed Circuit Board	LINFINITY LXE1721 DC2601		Rev.	1
5	Inductor, 15uH	ISI # RL622-150K	TH	L1, L2, L3, L4	4
6	Phono Jack, 90° Nickel Plated, White	MOUSER 161-4214	TH	RCA1	1
7	Phono Jack, 90° Nickel Plated, Red	MOUSER 161-4215	TH	RCA2	1
8	Header, Str. .100" Center, 2Pos	AMP 87220-2	TH	J1, J2, JP2, JP2A, JP7	5
9	Header, Str. .100" Center, 3Pos	AMP 87220-3	TH	JP3	1
10	Header, Double Row .100" Center, 6Pos		TH	JP4	1
11	Shorting Jumpers, Open Top, Black	3M 929950-00 AMP 531220-7 SULLINS STC02SYAN	TH	J1, J2	2
12	Terminal Block 2Pos 5mm	BLOCK MASTER 301-021-1000	TH	JP1, JP5, JP6	3
13	Heat Sink Low-Cost for DIP	WAKEFIELD 651B	SMT		4
14	Epoxy, Thermal Conductive	WAKEFIELD 156K			

CAPACITORS

Line Item	Part Description	Manufacturer & Part #	Case	Reference Designators	Qty
1	Capacitor, COG, 18pF, 50V, 5%	NOVACAP 0805N180J500NT AVX 08055C180JAT2A	0805	C9, C11	2
2	Capacitor, COG, 100pF, 50V, 5%	NOVACAP 0805N101J500NT AVX 08055C101JAT2A	0805	C7	1
3	Capacitor, COG, 150pF, 50V, 5%	NOVACAP 0805N151J500NT AVX 08055C151JAT2A	0805	C10, C12	2
4	Capacitor, COG, 220pF, 100V, 5%	AVX 08055C221JAT2A	0805	C25, C26, C27, C28	4
5	Capacitor, X7R, 100nF, 50V, 20%	AVX 08055C104MAT2A NOVACAP 0805B104M500NT SAMSUNG CL21B104MBNC	0805	C2, C8, C16, C19, C22, C35, C36, C37, C38	9
6	Capacitor, Tant 1uF, 25V, 10%	KEMET T491A105K025AS	3216	C13	1
7	Capacitor, Tant 4.7uF, 16V, 20%	KEMET T491A475M016AS AVX TAJA475M016R	3216	C17, C20	2
8	Capacitor, Stacked MF 0.47uF, 50V, 5%	PANASONIC ECQ-V1H474JL	TH	C3, C4, C5, C6, C31, C34	6
9	Capacitor, Stacked MF 0.68uF, 50V, 5%	PANASONIC ECQ-V1H684JL	TH	C29, C30, C32, C33	4
10	Capacitor, Alum Elect. 47uF, 50V	PANASONIC ECA-1HM470I	TH	C18, C21	2
11	Capacitor, Alum Elect. 1000uF, 25V	PANASONIC EEU-FC1E102	TH	C1	1

RESISTORS

Line Item	Part Description	Manufacturer & Part #	Case	Reference Designators	Qty
1	Resistor, 10K, 5%, 1/8W	ASJ CR21J103T	0805	R1, R3, R22, R23	4
2	Resistor, 24.3K, 1%, 1/8W	ASJ CR21F2432T	0805	R16, R17, R18, R19	4
3	Resistor, 34.8K, 1%, 1/8W	ASJ CR21F3482T	0805	R5	1
4	Resistor, 56.2K, 1%, 1/8W	ASJ CR21F5622T	0805	R2, R4	2
5	Resistor, 5.1 Ohm, 5%, 1W	KOA RM73B3A5R1J ROHM MCR100JZHJ5R1	2512	R8, R9, R10, R11, R12, R13, R14, R15	8
6	Resistor 15 Ohm, 5%, 1W	KOA RM73B3A150J ROHM MCR100JZHJ150	2512	R20, R21	2
7	Resistor, Low Value Flat .020	IRC LR2010-01-R0200-F	2512	R6, R7	2

BOARD LAYOUT

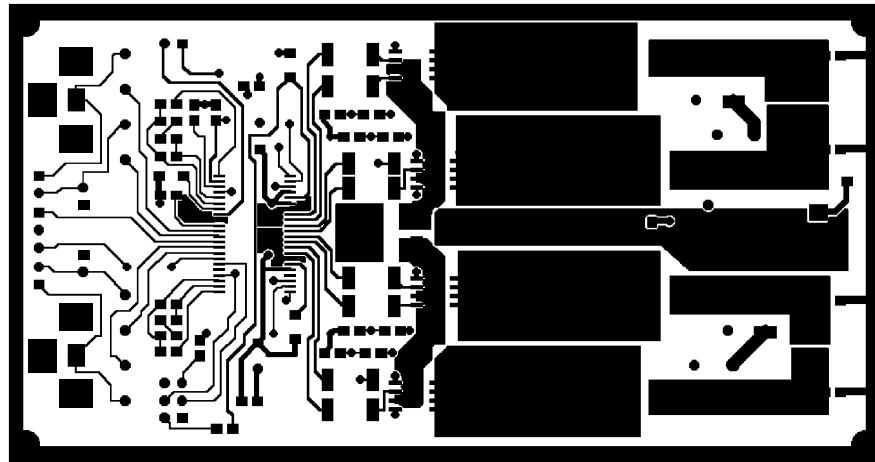

FIGURE 2 - COMPONENTS LAYER LAYOUT

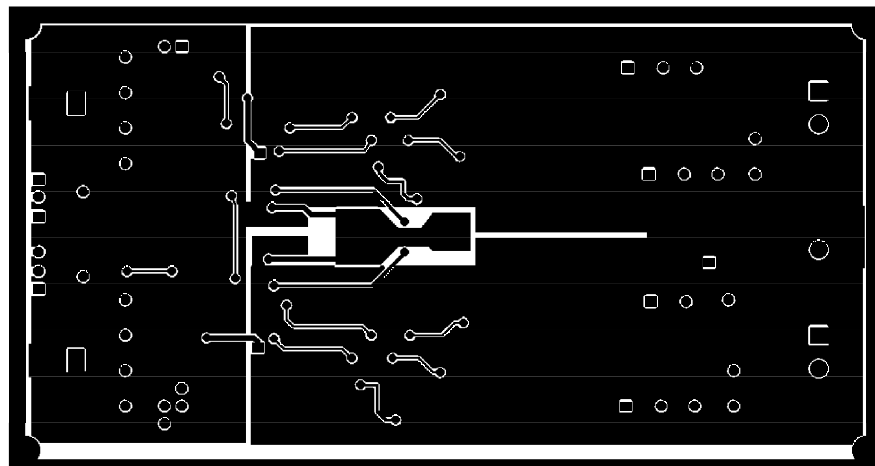

FIGURE 3 - SOLDER LAYER LAYOUT

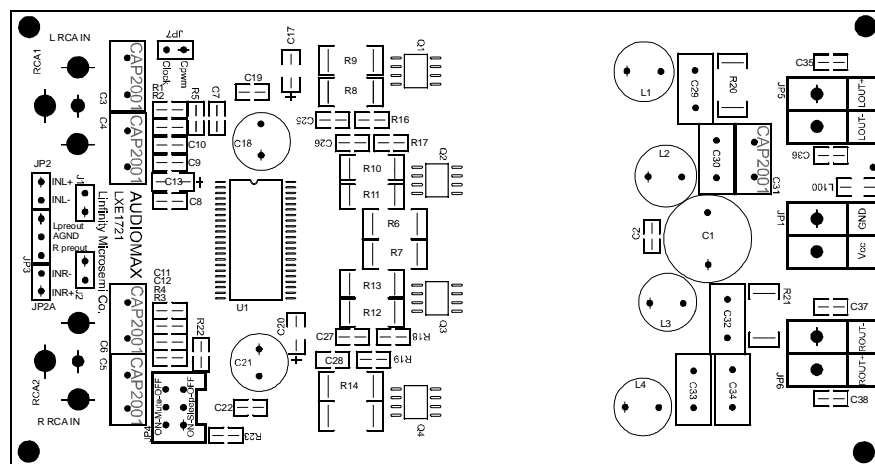

FIGURE 4 - LXE1721 COMPONENTS PLACEMENT

ABSOLUTE MAXIMUM RATINGS

Unless otherwise specified, the following specifications apply over the operating ambient temperature $0^{\circ}\text{C} \leq T_A \leq 70^{\circ}\text{C}$

Parameter	Symbol	Test Conditions	LX1721			Units
			Min	Typ	Max	
Supply Voltage	VCC		7		15	V
Supply Current	IDD	VCC=15V			6	A
Quiescent Current	IQ	VCC=15V, Output Open		75		mA
Sleep, Status		VCC = 15V	-0.3		VCC + 0.3	V
RPWM,CPWM, Mute		VCC = 15V	-0.3		VCC + 0.3	V
LIN+, LIN-, RIN+, RIN-	VIN	VCC = 15V	-0.3		VCC + 0.3	V
LPREOUT, RPREOUT	VPRE	VCC = 15V	-0.3		VCC + 0.3	V
Clock Frequency	FOSC	VCC = 15V	250	330	500	KHz